

## GOVT.86 PREP FOR DOORS-ALL SERIES

STANDARD MORTISE LOCK PREP(FULL TRIM) PER ANSI/BHMA A 156.115

AS DESIGNED FOR USE IN  
STANDARD SEAMWELDED EDGE DOORS

AS DESIGNED FOR USE IN  
STANDARD LOCKSEAM EDGE DOORS

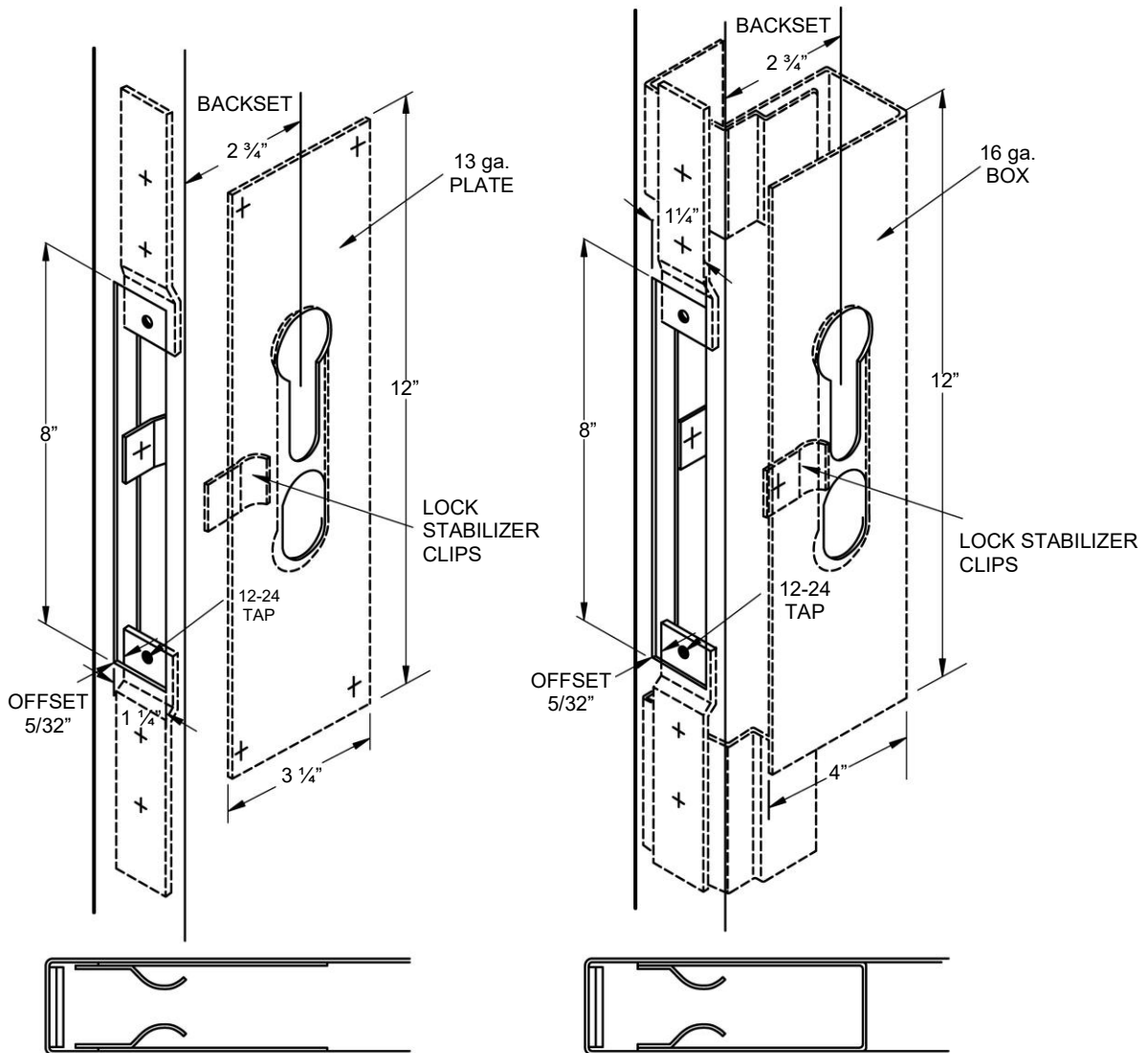

Dimensions and sizes shown are standard for this feature.  
Variations to suit designed conditions are available.